



## Hemmer – Adjustable

The Adjustable Hemmer will give you an endless variety of hem widths, all within one attachment.

With its scale closed, the attachment will make hems up to one inch wide. To create hems of a wider width, the scale may be released and thrown out of position.

Remove your presser foot and attach the Hemmer to the presser bar, taking care that the needle comes in the center of the needle hole after you tighten the thumb screw.

To adjust the Hemmer, loosen the screw and move the hemmer guide to the right or to the left. The point (A) is used in conjunction with the scale of figures on the hemmer.  
(Photo from Singer instruction manual)

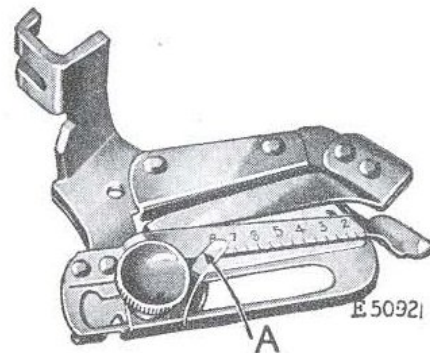

Photo from Machine Sewing by Singer. 1924

Move the pointer as follows (approximately) for the various hems:

Scale Number	Hem, in inches
1	3/16"
2	1/4"
3	3/8"
4	1/2"
5	5/8"
6	3/4"
7	7/8"
8	15/16"



### **Insert the Material**

Fold over the edge at the end of the material to be hemmed, as instructed previously for starting a hem with the Foot Hemmer. Place the material in the Hemmer under the scale and draw it back and forth until the hem is formed

You can now determine the width and to fold over the end of the hem for the second turning. Draw the material back until the end comes directly under the needle.

Lower the presser bar and begin sewing, always guiding sufficient material into the Hemmer to create your hem properly.

### **Soft Materials**

When you are hemming soft materials that may stretch, it is a good idea to slip a piece of paper or interfacing under the Hemmer next to the feed. This prevents the material from stretching and will assist in turning your hem.

### **Making a Wide Hem**

To make a hem more than one inch wide, loosen the screw, draw the slide to the right as far as it will go, and turn it towards you; throwing the scale guide out of position. Fold and crease down a hem of the desired width, pass the fold under the extension at the right of the hemmer, then insert the edge of the material into the folder, and proceed to sew. The Hemmer will turn the edge and stitch it flat; however, it is up to you to keep the crease for the width of the hem even as the machine sews.

This will allow you to make hems from 3/16" to 15/16" wide

### **Silver and Black Hemmers**

*I have seen many ads stating the black hemmers are 'rare'. Granted, they might be a little harder to find than the others, but I always have at least 3 or 4 in my attachment box at all times. They were produced when materials such as chromium, nickel, and aluminum was at a minimum during the war.*

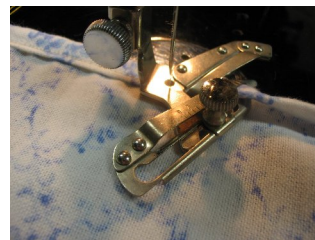

*Happy Stitching!*

*Charlene*

***THE SEW BOX***

<http://thesewbox.blogspot.com>

[www.thesewbox.com](http://www.thesewbox.com)